

CAPOTTINA BASE 3C/4C

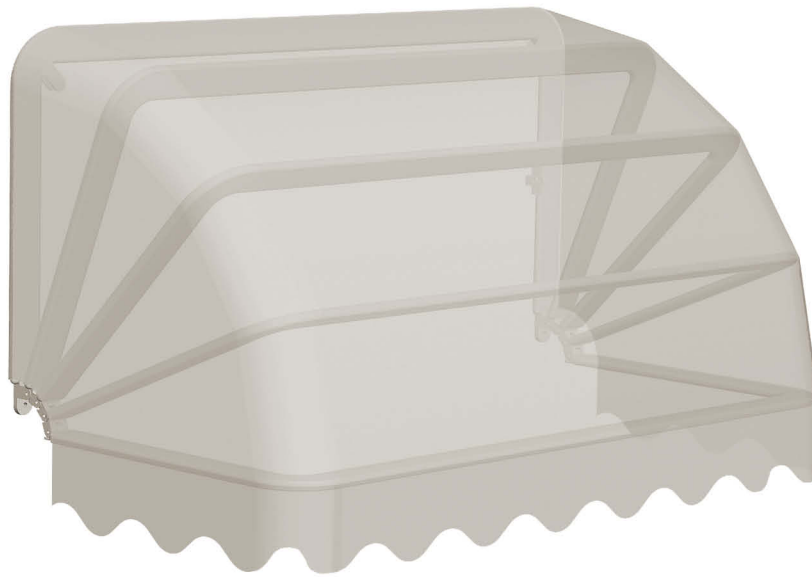

Tende con richiamo a fune, particolarmente indicate per esercizi commerciali ed in genere vetrine e finestre. Struttura verniciata con polveri poliestere presso il nostro stabilimento seguendo rigidi standard qualitativi. Struttura con telaio in lega estrusa e articolazioni in resina termoplastica, oppure in alluminio. Installabile sia a parete, che a soffitto o in "spallina".
 - Larghezza massima mt. 5.00
 - Sporgenza massima mt. 1.60.

Opening and closing cable awning, ideal for shops and for windows. Painting by polyester powder in our factory performed following rigid qualitative standards. Frame made of extruded alloy and articulated joints of thermoplastic resin or in aluminium.
 Installation on wall, on ceiling or for inside mounting.
 - Maximal width mt. 5.00
 - Maximal projection mt. 1.60.

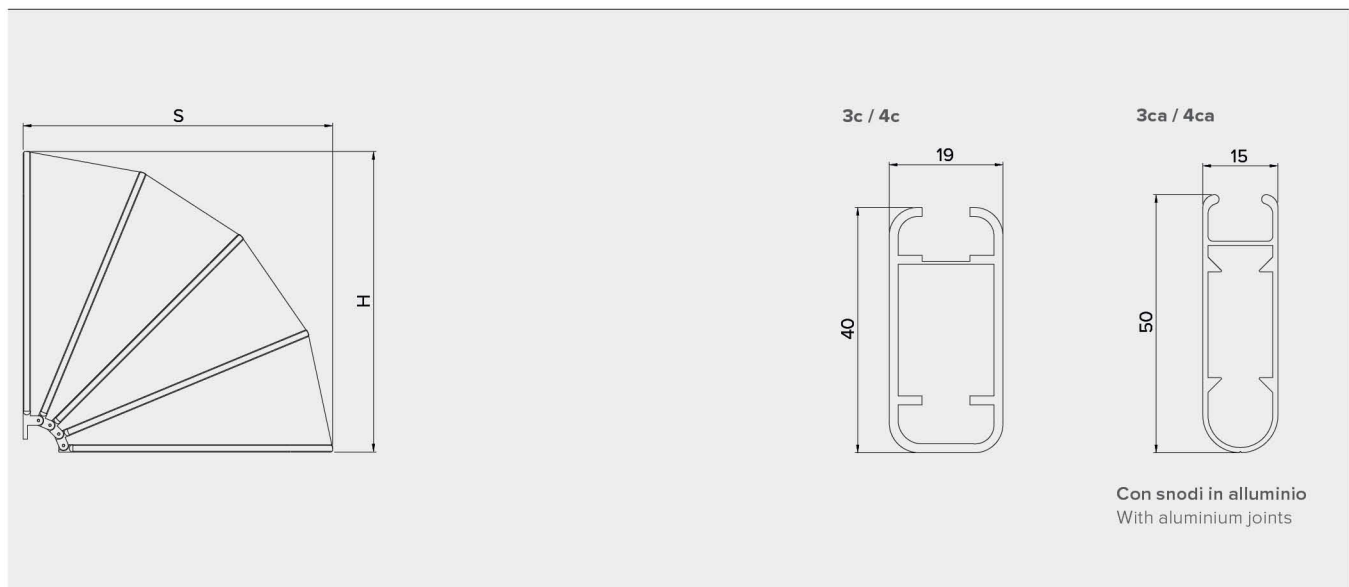

Standard



Optional



NO CRISTAL



Mod. 2
 art. 027-201
 +027-601 027-911